

# OWNERS GUIDE TO INSTALLATION AND OPERATION

# Fully Automatic Water Softeners



SINGLE TANK  
CABINET MODELS



TWO TANK MODELS

## SAFETY INFORMATION

- Read the instructions carefully and learn the specific details regarding installation and use. Failure to follow them could cause serious bodily injury and/or property damage.
- Make certain the electrical outlet is grounded by having it checked by an electrician or by using a UL Listed Circuit analyzer. Units are furnished with 3-prong grounded plugs to protect you against the possibility of electrical shock.

**⚠ WARNING** *Do not under any circumstances remove the ground prong and never splice or cut the electrical cord.*

- The outlet must be within reach of the power cord. Do not use an extension cord. Extension cords that are too long or too light do not deliver sufficient voltage to the unit and could present a safety hazard if the insulation

were to become damaged. The receptacle should be located four (4) feet above the basement floor to guard against the possibility of immersion.

**⚠ WARNING** *Disconnect power at the main electrical box before installing or servicing the unit. Do not plug in unit or change fuses while standing on wet or damp surfaces and do not touch any other metal surfaces while plugging in product or changing fuses. Do it with one (1) hand while keeping the other hand free.*

- Check to be sure your power source is capable of handling the voltage requirements of the unit. Plug into a dedicated grounded receptacle which contains a fuse or circuit breaker of 20 amps or less.
- All water treatment installations must conform to local plumbing, electrical and sanitation codes. These codes are established for your protection.

**INSTALL WATER CONDITIONER IN AN AREA PROTECTED FROM FLOODING, RAIN, DIRECT SUNLIGHT, DUST, SNOW AND FREEZING. THE WARRANTY DOES NOT COVER DAMAGE INCURRED AS A RESULT OF EXPOSURE TO WEATHER.**

# IMPORTANT NOTICE

## Pay Special Attention to the Following Points

- Installation must be made within a protected area covered from the elements and freezing. In areas where it is common practice to bury the unit in the ground, the unit must be protected from direct sunlight, rain, dust, flooding, snow and freezing. Failure to do so will void the warranty.
- Check plumbing inlet and outlet to ensure the proper flow of water through the unit. Match plumbing inlet and outlet with arrows located on the sides of the valve head and on the by-pass valve (especially if replacing an existing unit).
- Make sure the unit is plugged into a 115 volt grounded outlet which contains a fuse or circuit breaker of 20 amps or less.
- Do not run 1/2" I.D. semi-rigid drain tube over 20 running feet. If over 20 ft., increase drain line tubing size to 3/4" I.D. for the entire length of tube.
- Initially fill salt brine tank only 3/4 full with salt. (Do not pack full.)
- If any red rust stains are apparent, mix Super Iron Out® with the salt. As an alternative, there are types of salt available that contain iron control agents.
- After installing the unit, manually regenerate unit, following the control valve instruction manual.
- Make sure control head is correctly set for your specific water needs.
- If more than one unit is being installed, the regeneration/back wash times should be staggered.

***REMEMBER, YOUR PURCHASE IS AN INVESTMENT AND NEEDS TO BE MAINTAINED PROPERLY.***

If any parts are missing, damaged, unit does not seem to be working properly, or if you have any questions call

**1-800-545-2206 or 1-800-345-9422**

# TYPICAL INSTALLATIONS AND EQUIPMENT LOCATION

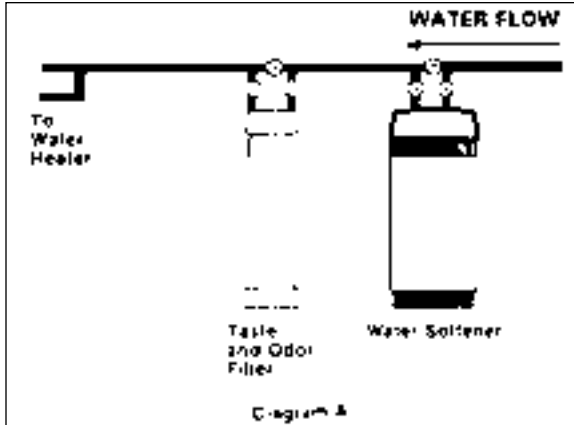

## LOCATE WATER CONDITIONING EQUIPMENT CORRECTLY:

1. Select the location of your water softener with care. Various conditions which contribute to proper location are as follows:
2. Locate as close as possible to water supply source.
3. Locate as close as possible to a floor or laundry tub drain.
4. Locate unit in correct relationship to other water conditioning equipment, if required. (See Diagram A.)
5. Select location where floor is level. If floor is rough and/or uneven, you can level by placing cabinet or tanks on 3/4" plywood, and shim to level as needed.
6. Locate the softener in the supply line BEFORE the water heater. Temperatures above 100°F (38°C) will damage the softener and void the factory warranty.

***Install water conditioner in an area protected from flooding, rain, direct sunlight, dust, snow and freezing. The warranty does not cover damage incurred as a result of exposure to the weather.***

7. Allow sufficient space around the installation for easy servicing.
8. Provide a non-switched 110/120V, 60Hz power source for the control valve.

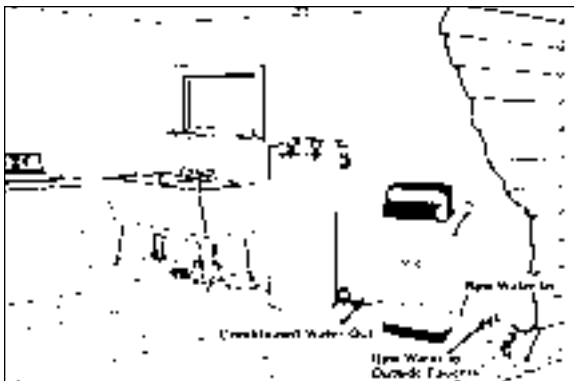

Typical first floor installation for utility room or breezeway, where floor drain exists.

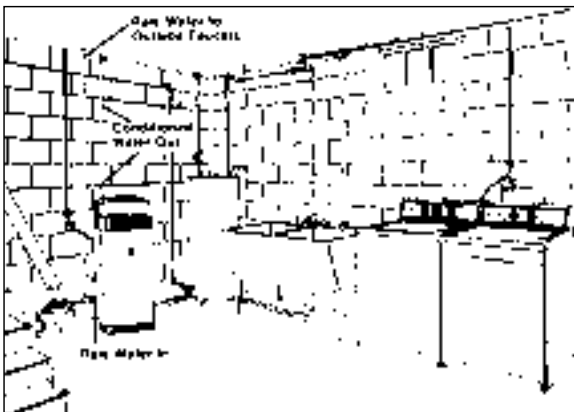

Typical basement installation uses overhead piping with floor or wash tub drain outlet.

# INSTALLATION INSTRUCTIONS



1. Water softeners are available in several styles. Installation is essentially the same for all of them.

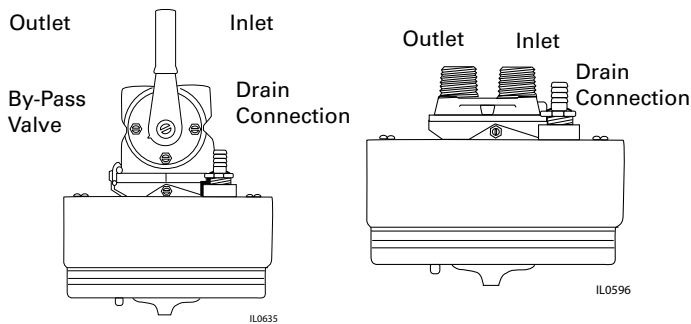

2. Units with a by-pass valve (left) use a 3/4" female threaded inlet/outlet, units with a yoke or manifold (right) use a 3/4" male threaded inlet/outlet

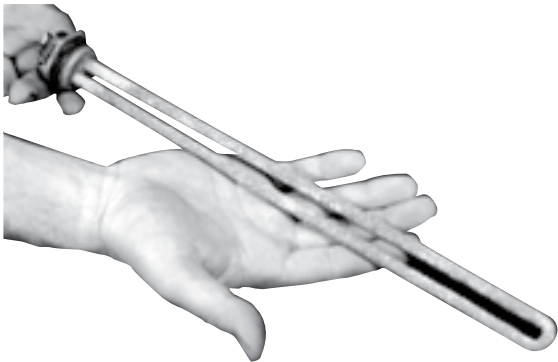

3. The above water heater element shows the effect hard water buildup has on water heaters. Scale buildup from hard water is dramatically increased when water is heated.



4. Install the unit in the water line ahead of the water heater, close to a drain, and a 115 volt grounded outlet on a flat surface.

**NOTE:** Make sure electric outlet is grounded and cannot be turned off by a wall switch or pullchain.



5. Remove the salt compartment cover from single tank units or the brine tank lid from two tank units.



6. Position softener near main water supply line, drain and electrical outlet. Position so main water supply shut-off valve is between softener and main water source.

**NOTE:** Install unit in an area protected from the elements and freezing.



7. Close main water supply shut-off valve.



8. Open nearest faucet to relieve pressure and drain plumbing lines.



9. On a new installation not already plumbed for a water softener, cut out section of main water supply line downstream from the supply shut off, at position softener is to be installed.



10. Check inlet and outlet for correct water flow, matching arrows on valve head and on by-pass valve (especially if replacing an existing unit).  
**CAUTION:** Install in directions of arrows.

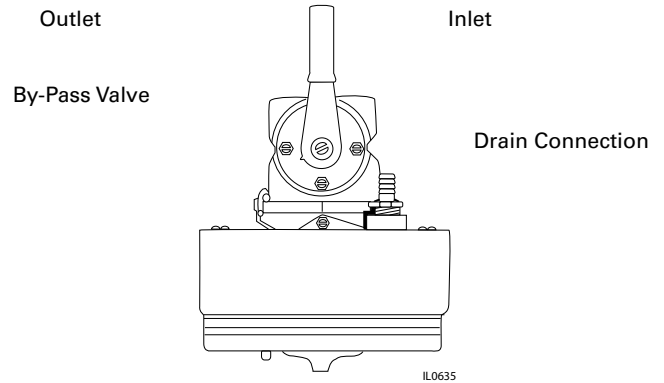

11. Above diagram shows unit installed with a by-pass valve. The unit can be removed easily without disrupting the plumbing. A 3-valve by-pass system (Figure 13) is not needed.

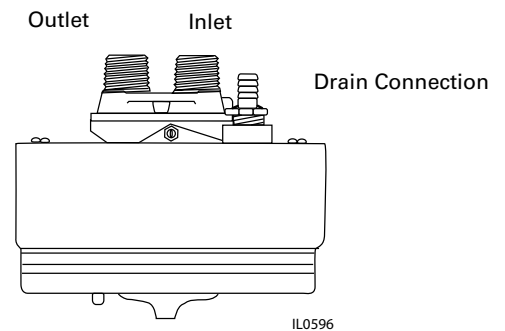

12. Above diagram shows unit with a 3/4" manifold. This installation requires a 3-valve by-pass system as shown in Figure 13.

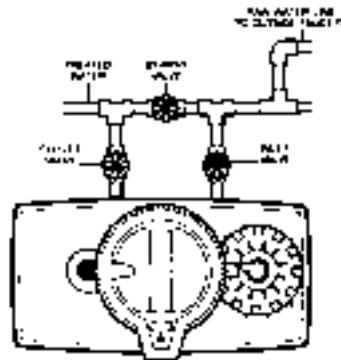

13. Above diagram shows a 3-valve by-pass system. Many new houses are plumbed water softener ready in this manner. A by-pass valve as shown in Figure 11 can be used with this system.

# INSTALLATION INSTRUCTIONS



14. Before installing 3/4" fittings to the inlet and outlet of the by-pass valve or manifold, wrap the threads 3 times around with Teflon tape. Install 3/4" fittings. **CAUTION:** Do not over tighten.

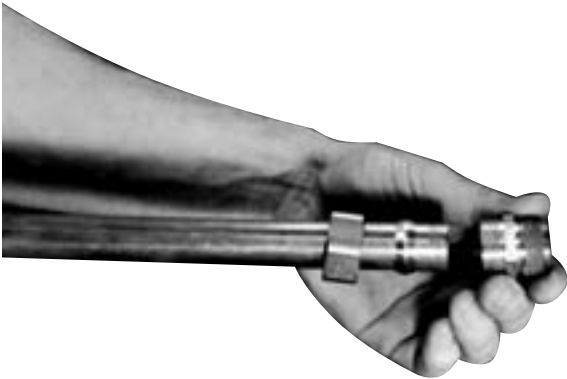

15. Soldering is no longer required to plumb with copper pipe. Instead, use 3/4" compression fittings. Connect plumbing as required for the specific application (see Figures 17, 18 & 19).

**CAUTION: IF COPPER PIPING WITH SWEAT FITTINGS IS USED, DO NOT SWEAT DIRECTLY INTO THE IN/OUT MANIFOLD OF SOFTENER VALVE OR BY-PASS VALVE. HEAT WILL DAMAGE PLASTIC PARTS.**

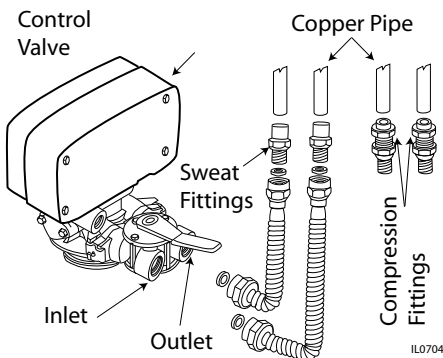

Connecting to Copper Pipe

16. Turn fittings clockwise with a wrench to tighten. Do not over tighten.

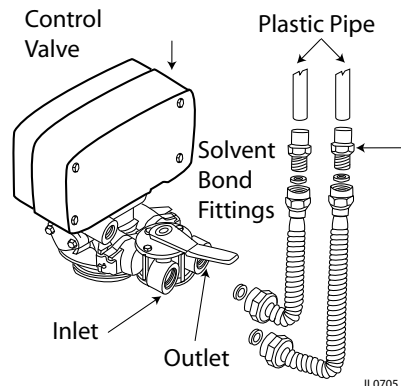

CONNECTING TO PLASTIC PIPE

17. Turn fittings clockwise with a wrench to tighten. Do not over tighten.

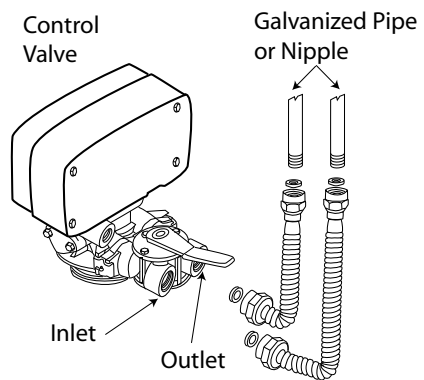

CONNECTING TO GALVANIZED PIPE

18. Turn fittings clockwise with a wrench to tighten. Do not over tighten.



19. Typical finished installation using rigid copper pipe. Make sure by-pass valve (if being used) is in the service position to ensure household service of treated water.

# INSTALLATION INSTRUCTIONS



20. Press 1/2" I.D. semi-rigid or non-collapsible plastic tubing (not included) onto drain line hose barb until snug and secure with a hose clamp (not included).

**NOTE:** Do not run 1/2" drain line over 20'. If over 20', increase tube size to 3/4".



21. Typical drain line to stand pipe with proper 4" air gap.

**NOTE:** An air gap is required by most local plumbing codes to prevent waste water back flow. Check and follow your local codes.



If you are installing a single tank unit, proceed to step 28.

22. Loosen compression nut located on right side of control valve by turning counter clockwise. Insert one end of 3/8" O.D. tube (included).

**NOTE:** This step has already been done on single tank design units.

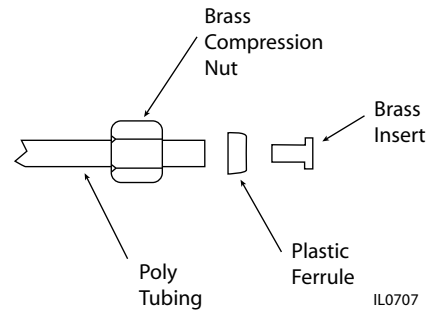

23. For 2 tank softener installations only, make sure you have the plastic ferrule in the right direction for an air tight seal.



24. Visually check brine tubing for cracks or kinks. Check fittings for proper assembly and tightness as diagrammed.



25. Turn compression nut clockwise with wrench to tighten.

**CAUTION:** Do not over tighten.

**NOTE:** This step is not required on single tank units.

# INSTALLATION INSTRUCTIONS



26. Insert other end of 3/8" plastic tube, from control valve, through hole on brine tank. Loosen compression nut, turning counter clockwise, and insert tubing.

NOTE: This step is not required on single tank units.



27. On 2 tank units only, turn compression nut clockwise with wrench to tighten.

CAUTION: Do not over tighten.

NOTE: This step is not required on single tank units.

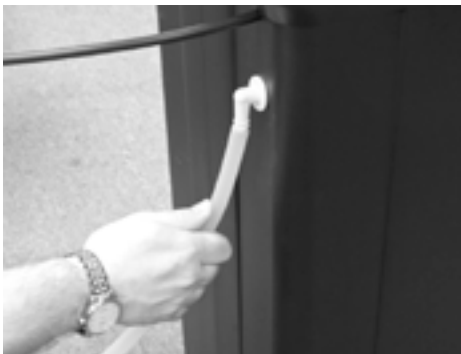

28. Install 1/2" I.D. semi-rigid or non-collapsible tubing (not included) to the overflow hose barb located on the side of the softener cabinet or brine tank and run to a suitable drain. Do not connect to drain line off of softener.



29. Plug cord from control valve into 115V grounded electrical outlet. Make certain that outlet is supplied with power at all times. Make sure area is dry before plugging the unit in.

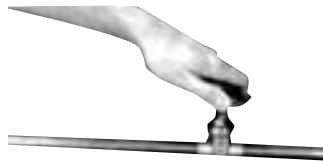

30. Open main water supply shut-off valve. CHECK FOR LEAKS! Close previously opened faucet (step 8).

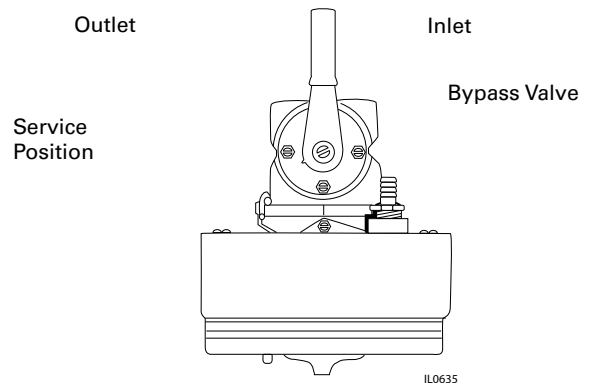

31. Make sure the bypass valve is in the service position as shown above. Rotate handle 90 degrees to go into the bypass position, and close off the valve when needed.

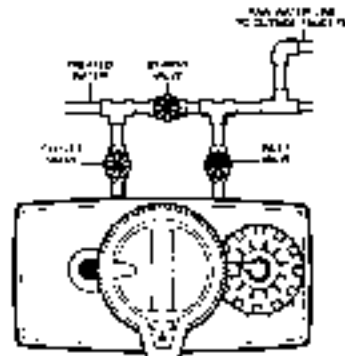

32. On a 3-valve by-pass system, open the inlet and outlet valves and close the by-pass valve (see diagram above).



# INSTALLATION INSTRUCTIONS

**TO PROGRAM THE CONTROL VALVE, SEE SEPARATELY ENCLOSED INSTRUCTION ENTITLED "SETTING THE CONTROL VALVE!"**



33. Draw a 5 gallon bucket of water to be used in the brine tank.



34. Pour the 5 gallon bucket of water into the brine tank. See Figure 42 for location of brine compartment on single tank models.



35. Measure 1-1/2 oz of chlorine bleach and pour solution directly into the brine tank or salt compartment on single tank units.



36. On all tank units, pour salt into compartment. Fill about 3/4 full initially. Do not pack full. This is also where iron control agents will be put if you have rust stains. Replace lids on the salt compartment.

# MAINTENANCE

- 1. SALT REFILL** - During each regeneration of the water softener, a specific amount of salt is consumed, thus requiring periodic replenishment. The frequency of the replenishment depends on the regeneration schedule. Always replenish salt before the supply is exhausted to ensure a continuous supply of softened water.  
  
We suggest using pellet type salt or grade A rock salt that contains no dirt or sediment. Fill tank about 3/4 full. Do not pack full. Do not use block salt. Potassium chloride, a salt substitute, can be used.
- 2. PREVENTING IRON FOULING OF MINERAL BED** - If iron is present in the water supply, the softener will eventually become iron fouled, resulting in reduced softening capacity and rust stained fixtures. Mixing one or two ounces of Super Iron Out® or similar iron cleaner with every 80 lbs. of salt added to the brine compartment will minimize these problems. As an alternative, there are types of salt available on the market that contain iron control agents.
- 3. BRINE COMPARTMENT CLEAN OUT** - To prevent service problems, the salt compartment should be emptied and accumulate. This clean out should be done when the salt level is low or exhausted.  
  
To eliminate the need of removing the brine tank (two tank models) or the entire unit (single tank models), use a wet/dry vacuum cleaner to empty the old brine water. Once emptied, clean dirt from the salt compartment. Add 5 gallons of water and new salt.
- 4. PERIODICALLY CHECK TIME OF DAY SETTING** - Power outages will cause time of day timer setting to become incorrect. To reset, refer to "Setting the Control Valve."
- 5. CHANGE OF OPERATING CONDITIONS** - Should your family size, your water usage habits or your water quality change, the regeneration program setting may have to be adjusted. Do not lower salt setting.

---

## PREVENTING WATER CONDITIONERS OR FILTERS FROM FREEZING WHILE IN STORAGE

NOTE: The warranty does not apply to damage due to freezing, nor is the manufacturer responsible for or assume any liability for breakage, missing parts or consequential damage that results from placing the unit into storage.

1. Plan Ahead! Placing the unit into storage should be done when the salt level in the brine tank is low but NOT completely exhausted.
2. Immediately before storage and before the salt is completely exhausted, manually start the regeneration process and allow the unit to automatically go through all of the regeneration cycles.
3. Place the unit into the by-pass position, depressurize and disconnect the plumbing from the control valve.
4. Remove the control valve from the mineral tank by turning counterclockwise.
5. Shake as much water out of the valve as possible and store in an open, dry area. Place any loose fittings in a plastic bag and tape to the valve.
6. Syphon water from the mineral tank, inserting a hose into and down the distributor tube. This tube is in the middle of the mineral tank and can be seen once the valve is removed.
7. Using a wet/dry vacuum cleaner, empty the brine tank/salt compartment of brine water. Then remove as much of the remaining salt as possible. CAUTION: Salt will become encrusted if allowed to remain in the brine tank.
8. Using two (2) people, place mineral tank or cabinet on its side on the floor, using caution as the cabinet or mineral tank will break if dropped or not handled carefully.  
  
CAUTION: Water from the mineral tank will cause damage to carpeting, vegetation, furniture, etc. The manufacturer of the equipment is not responsible, and assumes no liability for such damage.
9. DO NOT stand the unit upright until it is to be placed back into service. To do so will allow remaining moisture to settle to the bottom of the mineral tank, expand when freezing, thereby splitting the tank.
10. To place the unit back into service, refer to installation and control valve instructions.

# WATER SOFTENER TROUBLE SHOOTING

JUST INSTALLED UNIT AND WATER IS NOT SOFT	
WHAT TO CHECK	HOW TO CORRECT
Has unit been properly installed	Re-read instructions to see that all steps were followed
By-pass in plumbing	On a 3-way by-pass valve system, open valves on piping coming into and out of softener. The valve in between <b>MUST</b> be closed and in good condition. Most units include a by-pass valve which is connected to the control valve. Make certain that it is in the service position.
Is unit piped in backwards	Check arrows where pipe threads into valve head and make sure water is flowing consistent with the direction arrows are pointing.
Hot water tank hardness	Allow sufficient time for hardness that has built up in your water heater and pipes to run through system. Repeated flushing of the water heater tank can also be done.
Is there resin in tank	Softeners ship with resin already in the tank. Make sure the resin has not been emptied or dumped. Put a trouble light behind resin tank and you should be able to see the resin thru the mineral tank. The tank should be approx. 2/3 full.
Valve head is not working correctly and causing water flow not to go through softener	Shut off water supply, de-pressurize the unit*, unscrew the valve head from unit and exchange it.
Softener has been undersized and does not effectively remove the amount of hardness in your water	Draw a sample of untreated water before it goes through the softener and a sample of treated water after the softener. Have the samples analyzed to see if any hardness is being removed.
Water flow rate going through the softener is not allowing time for the unit to soften	Open an outside faucet and fill a measured bucket up with water for 1 minute. The amount of gallons in the bucket tells you how many gallons per minute are being run through the softener. Call 1-800-545-2206 to see what the GPM limit is on the specific unit you have purchased. Add a flow control accessory to your unit if needed.
*To depressurize the unit, refer to valve instructions for your particular unit.	

WATER TASTES SALTY OR BRINE TANK FILLS WITH WATER	
WHAT TO CHECK	HOW TO CORRECT
Is backwash water flowing freely down to drain with an air gap and no back siphoning	Put valve into "Backwash" position and follow water flow down to drain. If over 20 ft., use 3/4" (or larger) drain tubing. Drain line should be no more than 8 ft. lift.
Brine salt tube and connections not allowing salt solution into mineral tank to regenerate	Visually check tubing for cracks or kinks. Check fittings for proper assembly and tightness as diagrammed. <div style="text-align: center; margin-top: 10px;"> <p style="font-size: small; margin-top: 5px;">IL0707</p> </div>
Injector or injector screen plugged	Put softener in by-pass position and de-pressurize the unit by putting into "Backwash" position. There will be 2 screws on neck of valve where the salt rinse line goes into softener. Remove the 2 screws and clean screen and remove any chunks of salt, etc.

## WATER WAS SOFT BUT NOW FEELS HARD

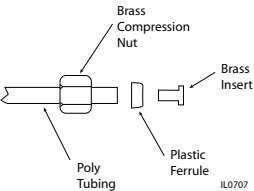
WHAT TO CHECK	HOW TO CORRECT
No salt in brine tank	Add salt to brine tank and maintain salt level above water level. Manually initiate the regeneration cycle and allow softener to totally go through all regeneration cycles.
Electrical service to unit has been interrupted	Make certain that the power cord is plugged into a 115V grounded outlet that cannot be turned off accidentally by a wall switch or pull chain. Check for blown fuses. In case of electrical power outages, reset the time of day. Some valves utilize a battery - see valve instructions for battery replacement.
Has softener valve head been programmed to regenerate after installation?	See valve programming instructions. Was water properly tested and diagnosed for correct setting? Have additional people moved in or water usage increased?
Has the by-pass been used and not connected back into service?	Make sure the handle of the bypass valve is in the service position. On a 3-way bypass position, open the inlet and outlet valves and close the bypass valve.
Salt is bridging in tank	Salt in bottom of tank has hardened and is not allowing water/salt mixture to get to the bottom of salt and consequently over to mineral tank. Do not fill salt tank completely (3/4 full). Use a stick or broom handle and poke into salt, making sure it is broken up.
Salt tube going from salt tank to mineral tank is plugged or insufficient water flowing into brine tank	Put unit into "Brine Rinse" position, make sure salt water flows uninterrupted from salt tank to mineral tank. Clean or replace brine valve. Clean and unplug necessary line so water flows uninterrupted.
Brine salt line and connections not allowing salt solution into mineral tank to regenerate	Visually check tubing for cracks or kinks. Check fittings for proper assembly and tightness as diagrammed <div style="text-align: center;">  <p style="text-align: right; font-size: small;">IL0707</p> </div>
Injector or injector screen is plugged	Put softener in "By-Pass" position and de-pressurize by putting in "Backwash" position. There are 2 screws on valve neck where salt line tube enters softener. Remove screws, clean screen and remove chunks of salt, etc.
Line pressure is too low	Line pressure must be at least 20 PSI at all times.
Is backwash water flowing freely down to drain with an air gap and no back siphoning?	Put valve into "Backwash" position and follow water flow down to drain.
Too much iron or tannins have fouled the bed	A water softener is only effective for up to limited amounts of iron and yellowish colored tannins. Draw water before it goes into and after it flows through softener. Have both samples tested to see if iron is being removed or if mineral bed is already coated and fouled.
Salt level setting on valve head is set too low	Verify salt setting and adjust as necessary (consult factory.)
Valve head or timer is not cycling	Shut off water supply, de-pressurize tank*, unplug unit and replace valve head motor.
Has softening mineral been exposed to freezing?	Freezing weather causes the resin to mush and become ineffective. Replace resin, properly insulate and shield unit from direct elements and freezing temperatures.
Leak in distributor tube	Check for cracks in distributor tube. Check "O" ring and tube inlet in bottom of valve. Replace if necessary.

\*To depressurize unit or backwash, refer to the valve instructions for your particular unit.